

# ADA Sport (PITOT PROBE)

Date	Sept 3, 2019	
Sheet 1 of 1		
Approved	PSS, Inc.	Drawn by JBF
Drawing #	S-200	Rev C

File Name	Functional Schematic Sport - Probe R2.dwg	
Advanced Flight Systems, Inc.		

Clean all mating surfaces prior to installation

Pressure test all systems for leaks prior to flight

Use acceptable methods, techniques and practices in accordance with DOT FAA circular AC 43.13-1A

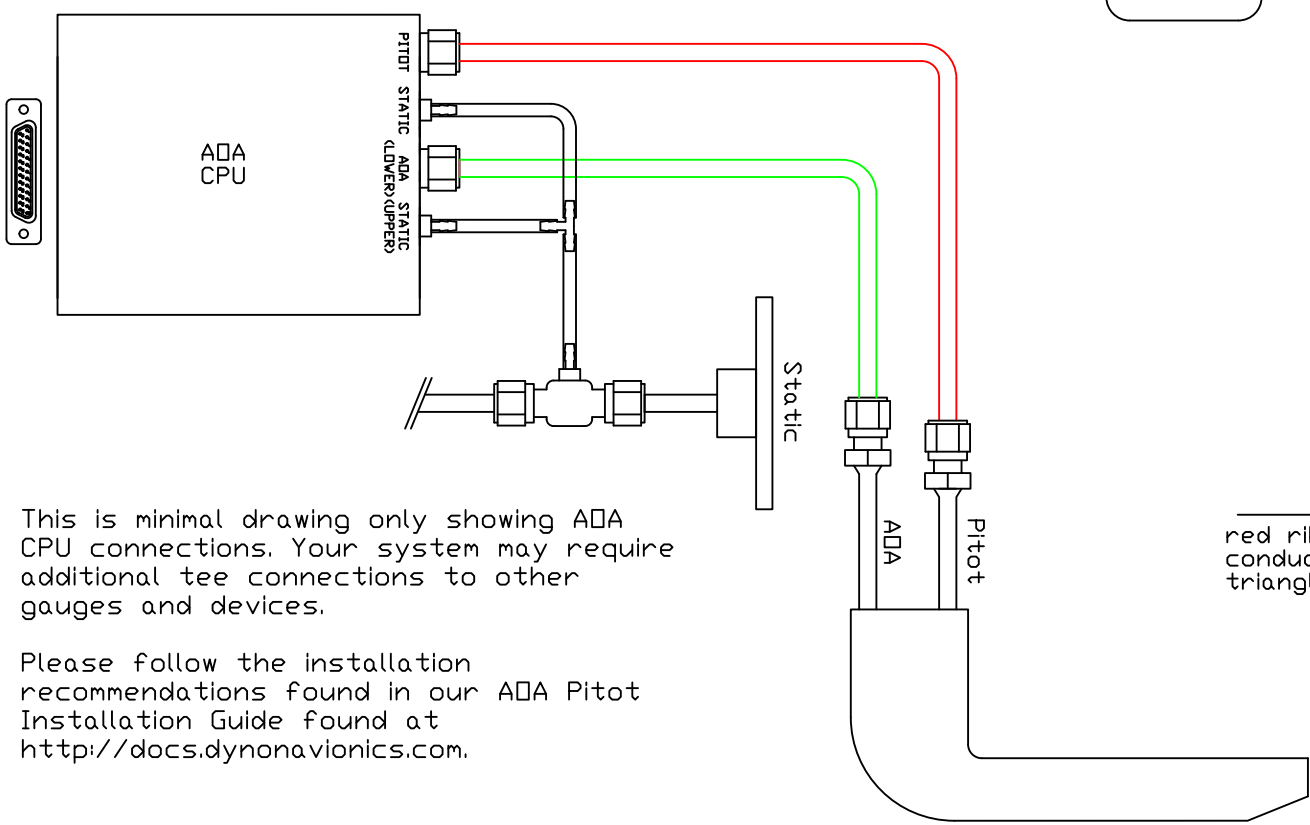

This is minimal drawing only showing ADA CPU connections. Your system may require additional tee connections to other gauges and devices.

Please follow the installation recommendations found in our ADA Pitot Installation Guide found at <http://docs.dynonavionics.com>.

Flap switch (FLAP)

Red Record & Push to Test (PTT)

26 ohm audio shield  
560 ohm audio ground  
use 560 ohm for audio panels with an internal amplifier otherwise use 26 ohm

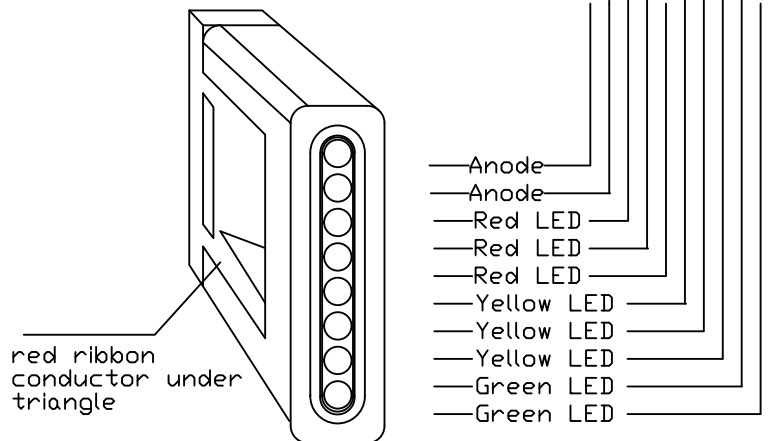
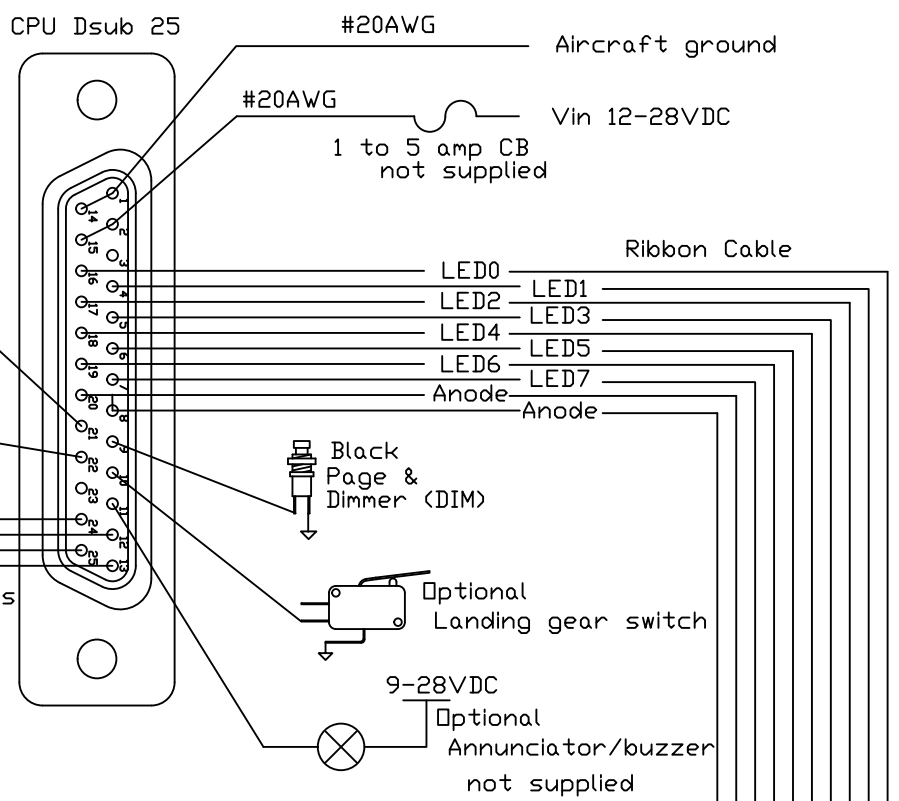

All wiring #22AWG MS22759 tefzel except as marked otherwise